

Service Schematics

NOKIA N92

RM-100

Introduction

Important:

This document is intended for use by authorized service centers only.

“Service Schematics“ was created with focus on customer care. The purpose of this document is to provide further technical repair information for NOKIA mobile phones on Level 3/4 service activities. It contains additional information such as e.g. “Component finder”, “Frequency band table” or “Antenna switch table”. The “Signal overview” page gives a good and fast overview about the most important signals and voltages on board. Saving process time and improving the repair quality is the aim of this document. It is to be used additionally to the service manual and other training or service information such as Service Bulletins.

All measurements were made using following equipment:

Nokia repair SW	:	Phoenix version 2006.04.6.136
Oscilloscope	:	Fluke PM 3380A/B
Spectrum Analyzer	:	Advanced R3162 with an analog probe
RF-Generator/GSM Tester	:	Rhode & Schwarz CMU 200
Multimeter	:	Fluke 73 Series II



Table of contents

Frontpage	1
System connector	2
Audio	3
AVILMA & BETTY	4
RAP3GS	5
OMAP & Combo memory	6
BT/FM & WLAN modules	7
User Interface	8
Upper block / connectors, audio & MMC	9
Upper block / DVB-H part	10
Upper block / Display	11
RF part	12
Signal overview	13
Component finder	14

While every endeavour has been made to ensure the accuracy of this document, some errors may exist. If the reader finds any errors, NOKIA shall be notified in writing.

Please send E-Mail to: training.sace@nokia.com

Copyright © NOKIA

This material, including documentation and any related computer programs is protected by copyright, controlled by NOKIA. All rights are reserved. Copying, including reproducing, modifying, storing, adapting or translating any or all of this material requires the prior written consent of NOKIA. This material also contains confidential information, which may not be disclosed to others without the prior written consent of NOKIA.

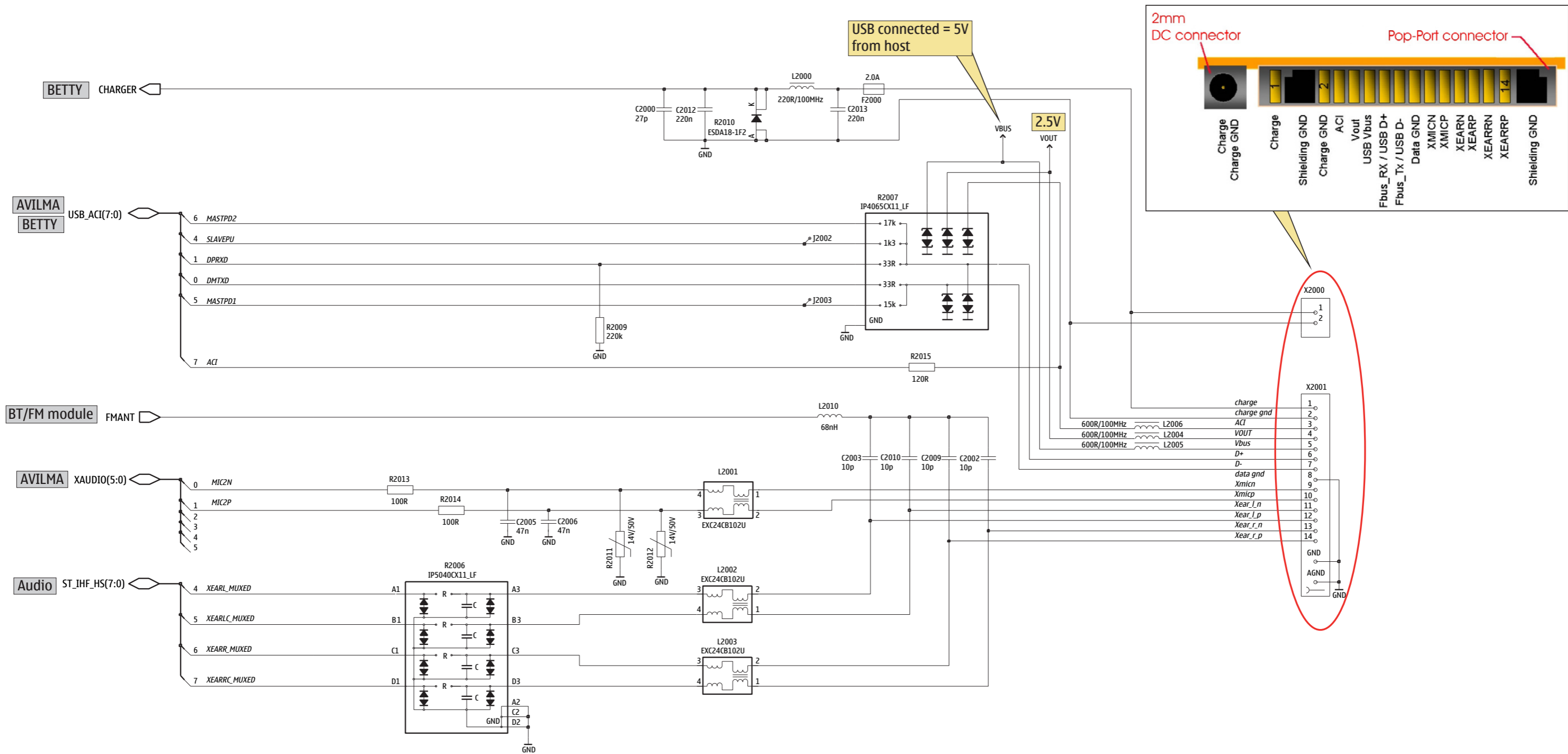

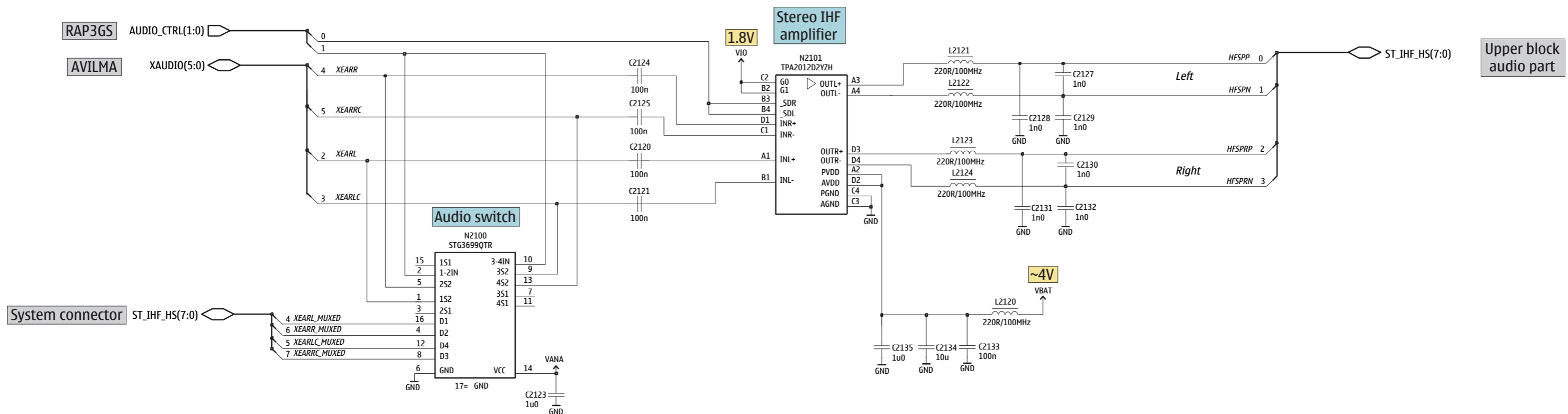

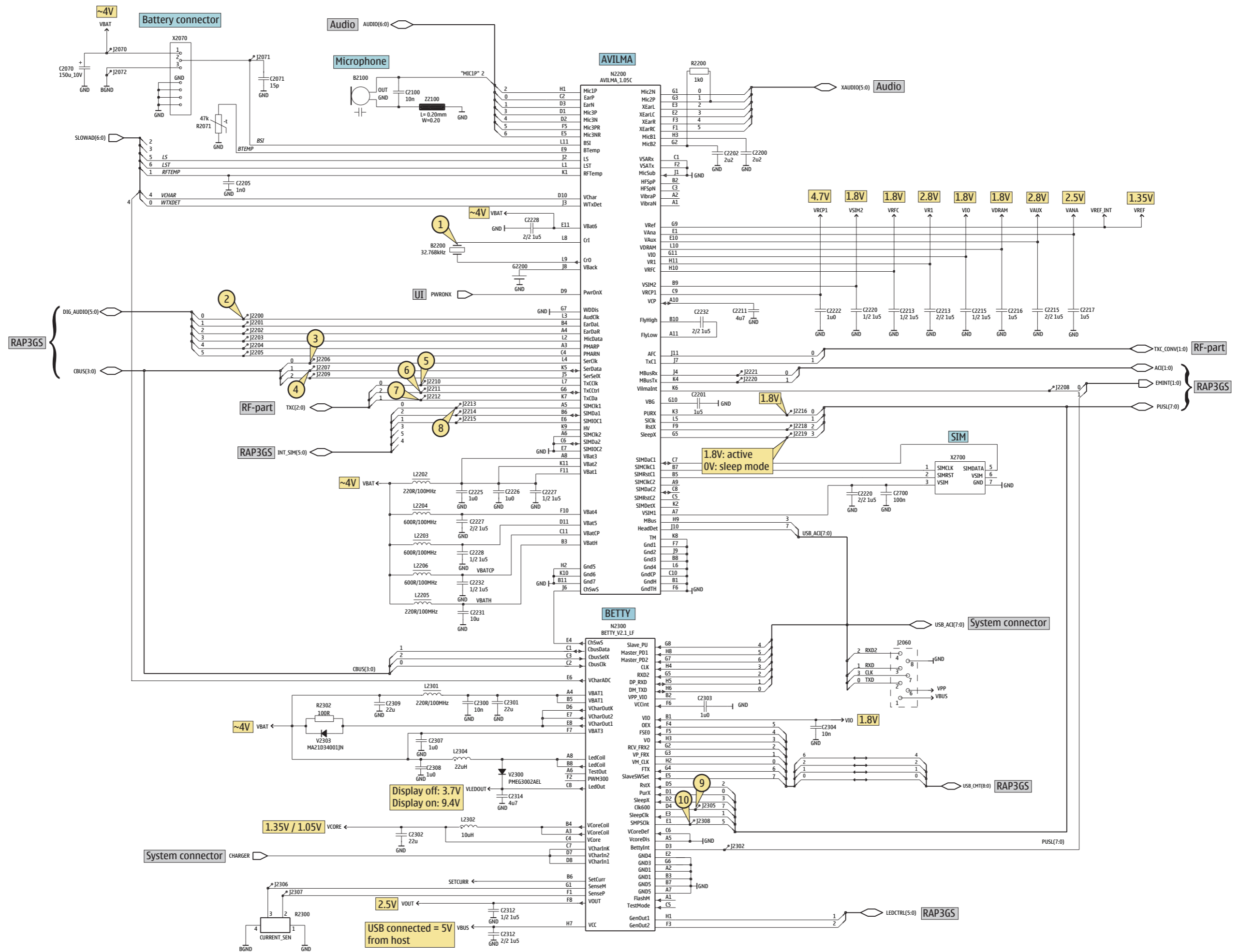

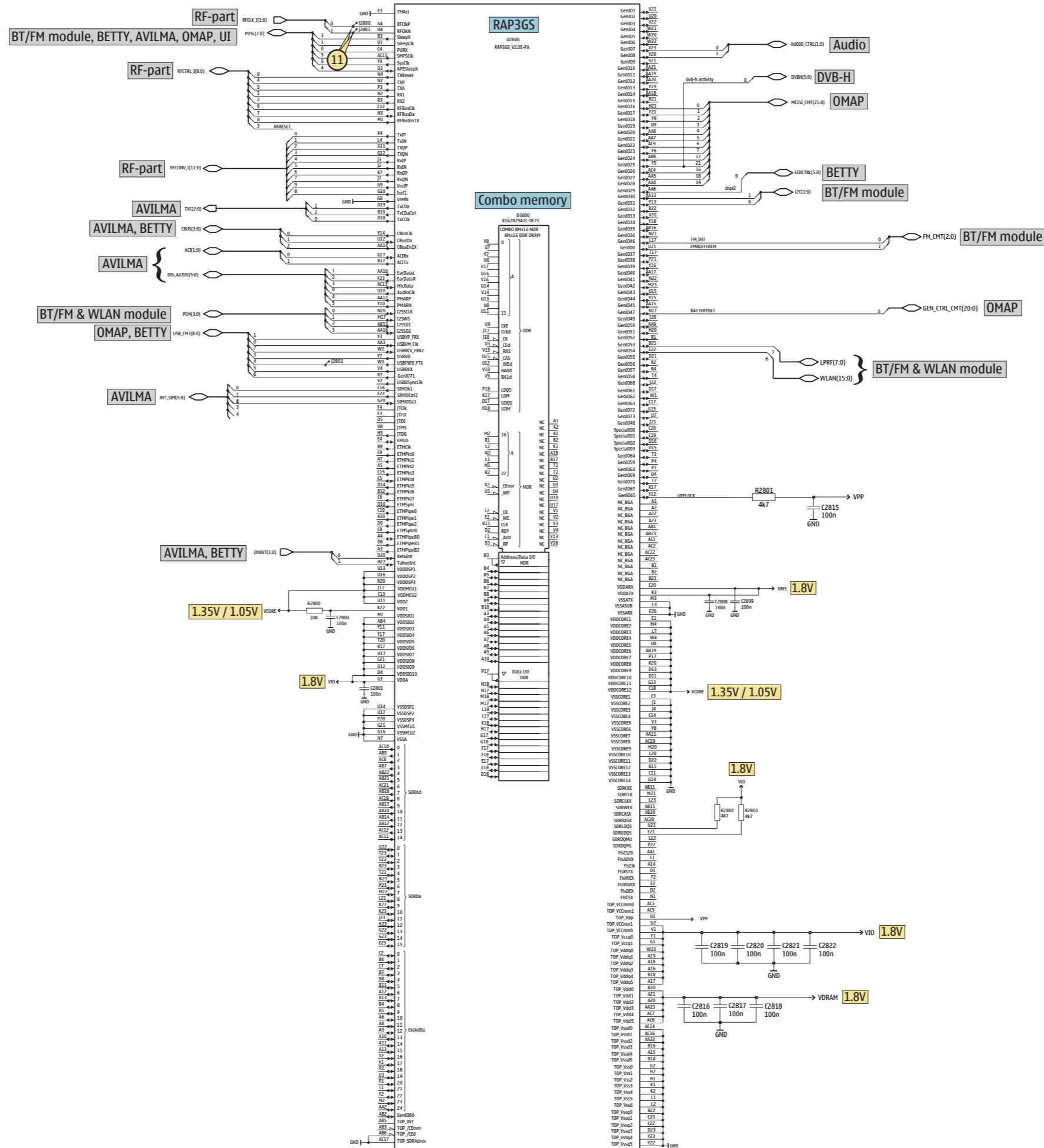

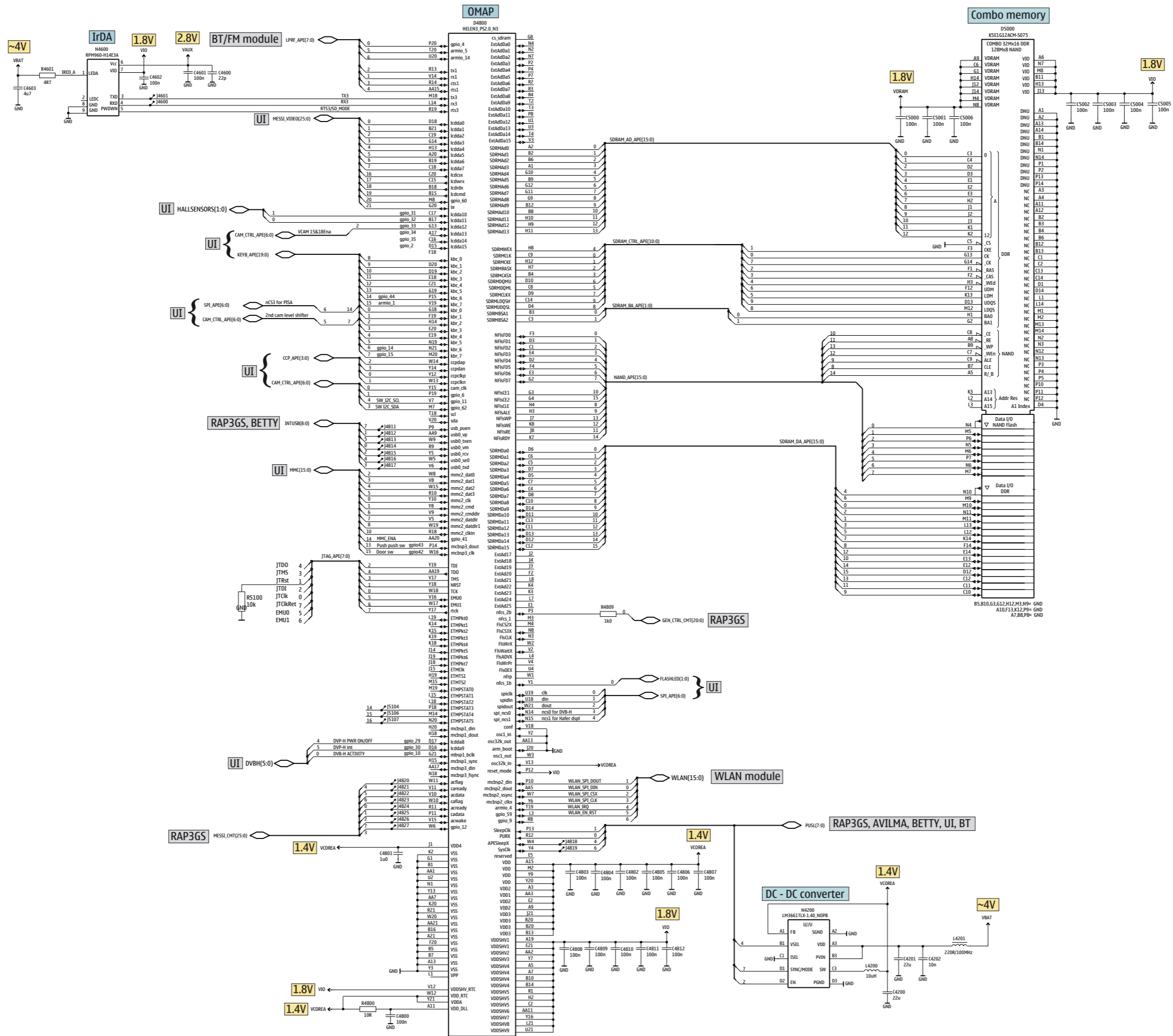

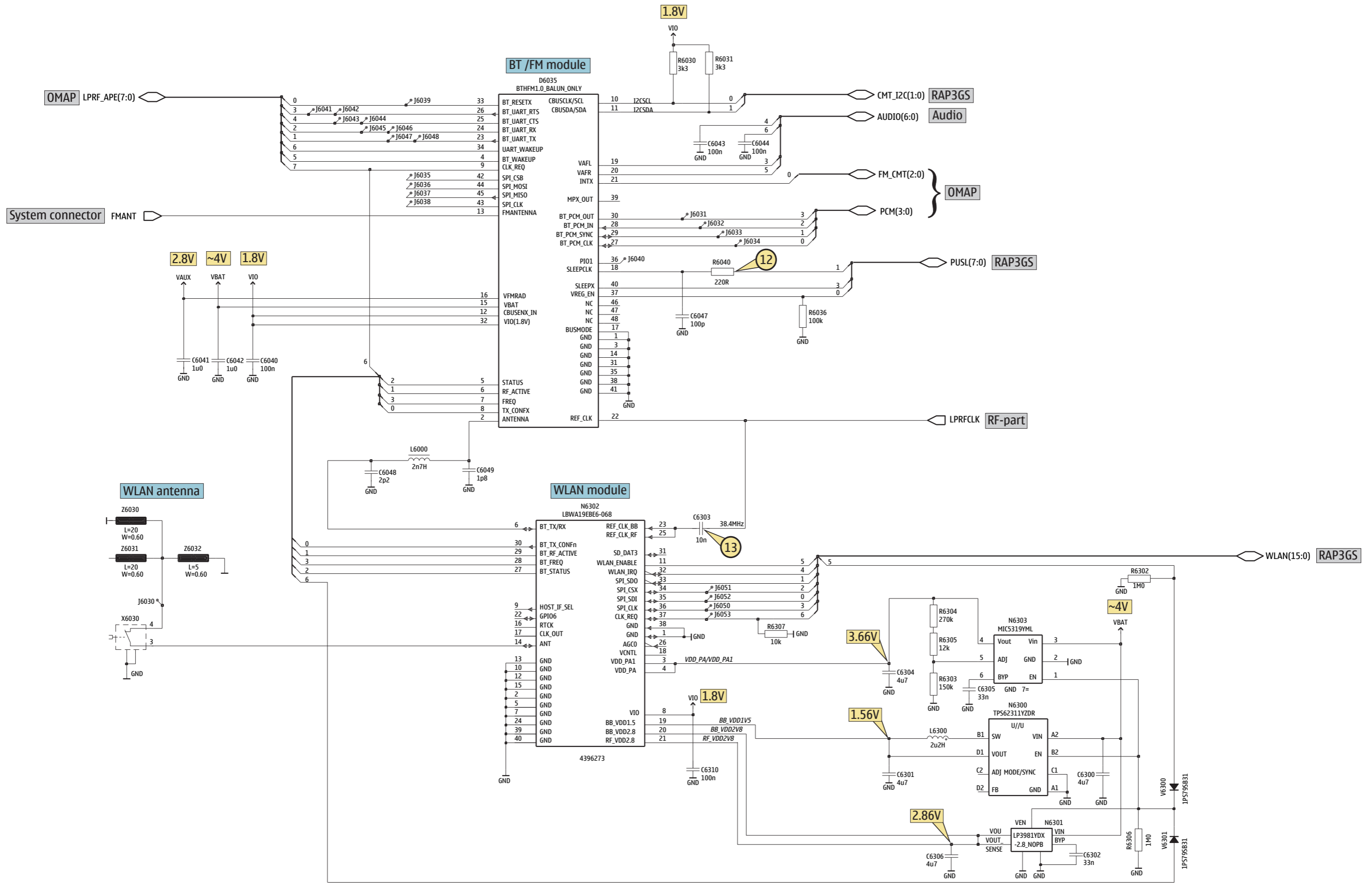

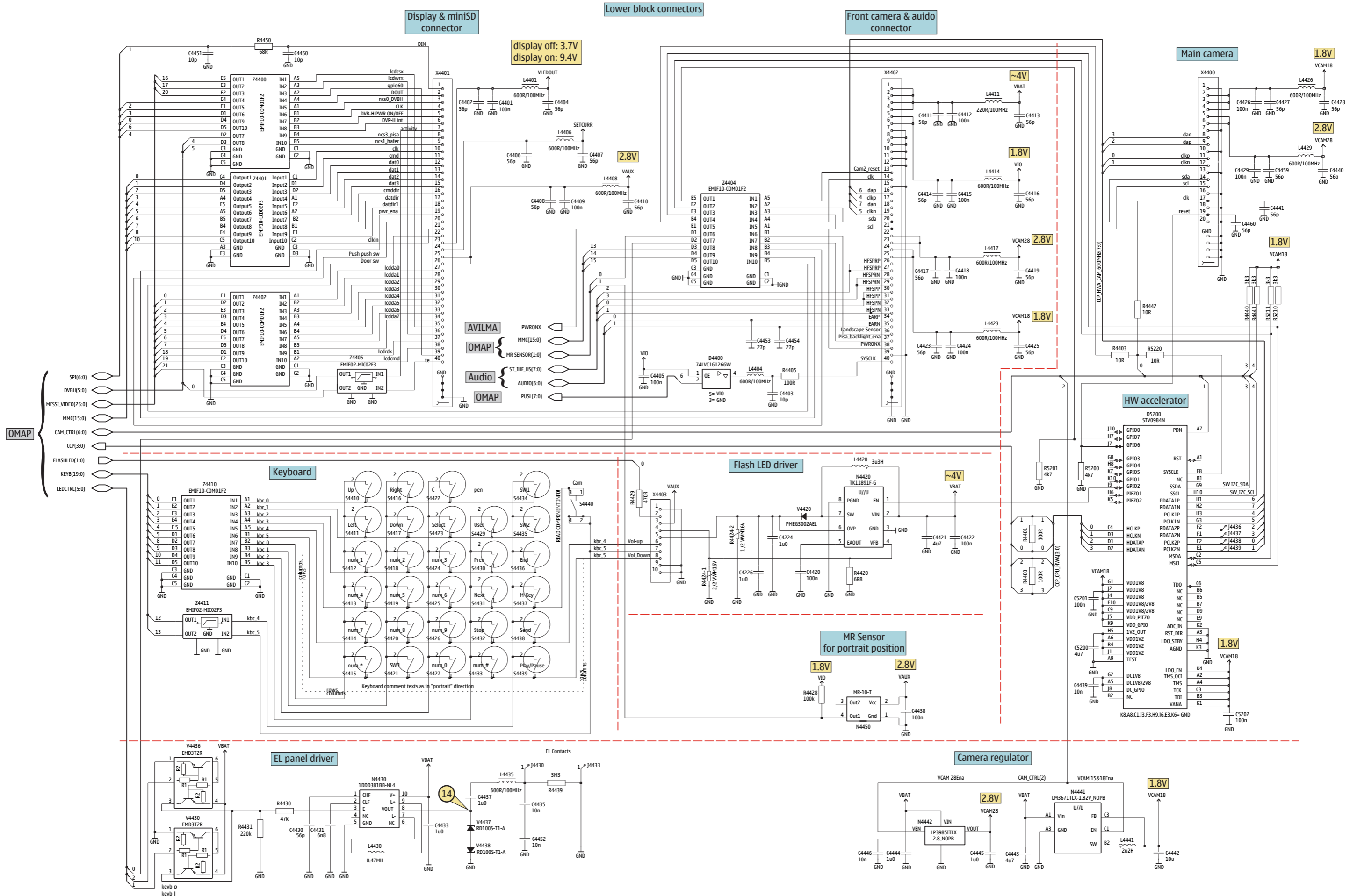

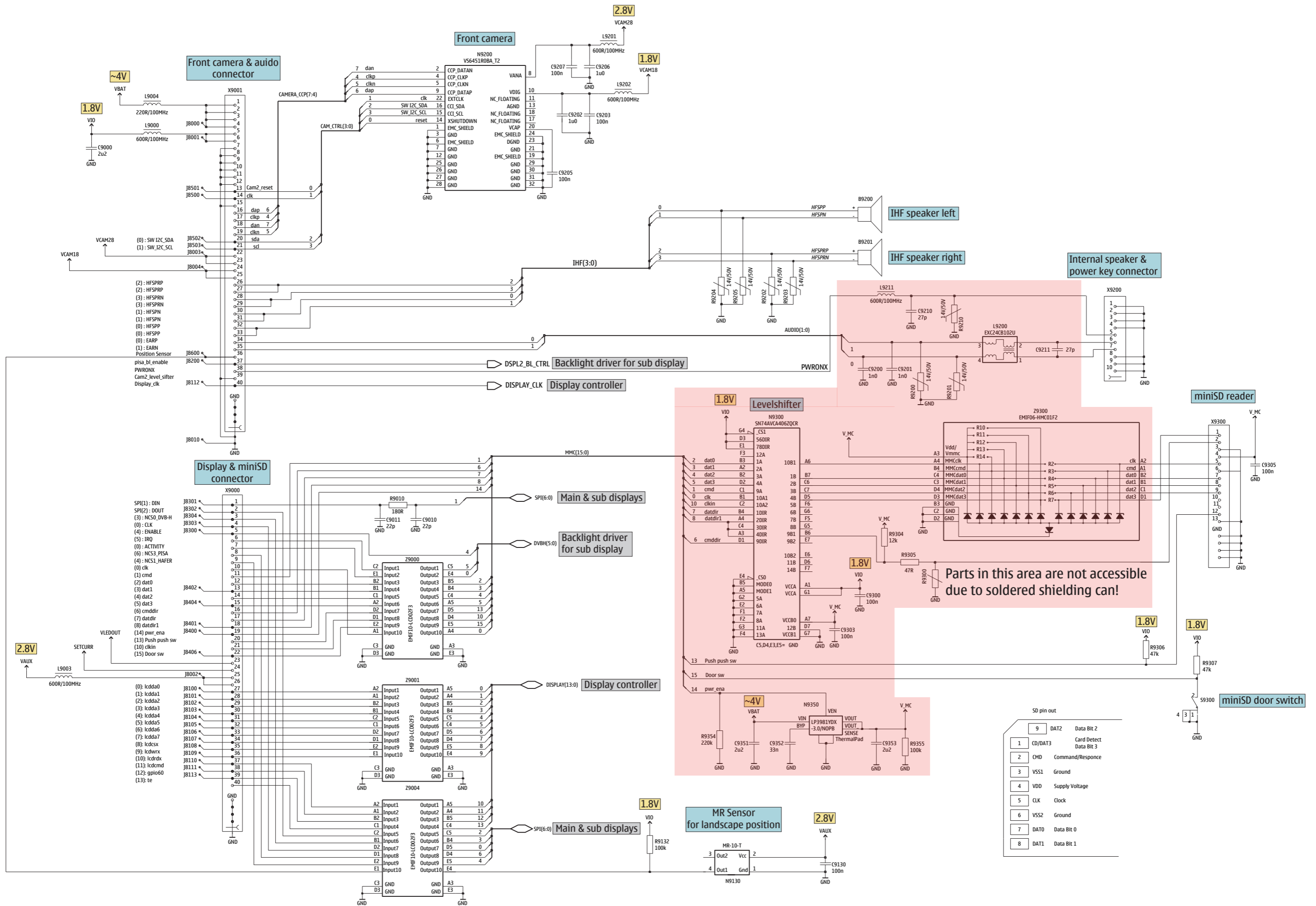

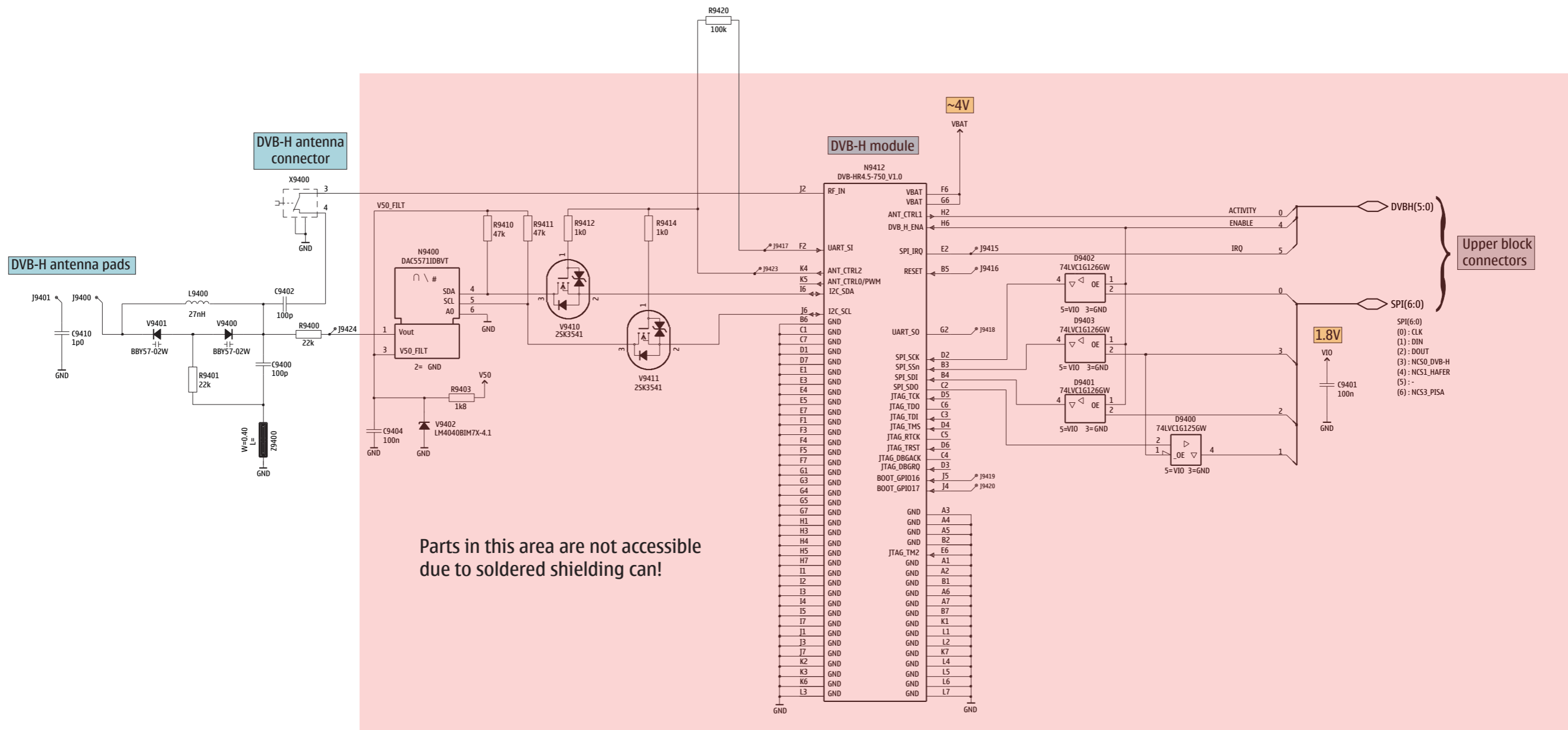

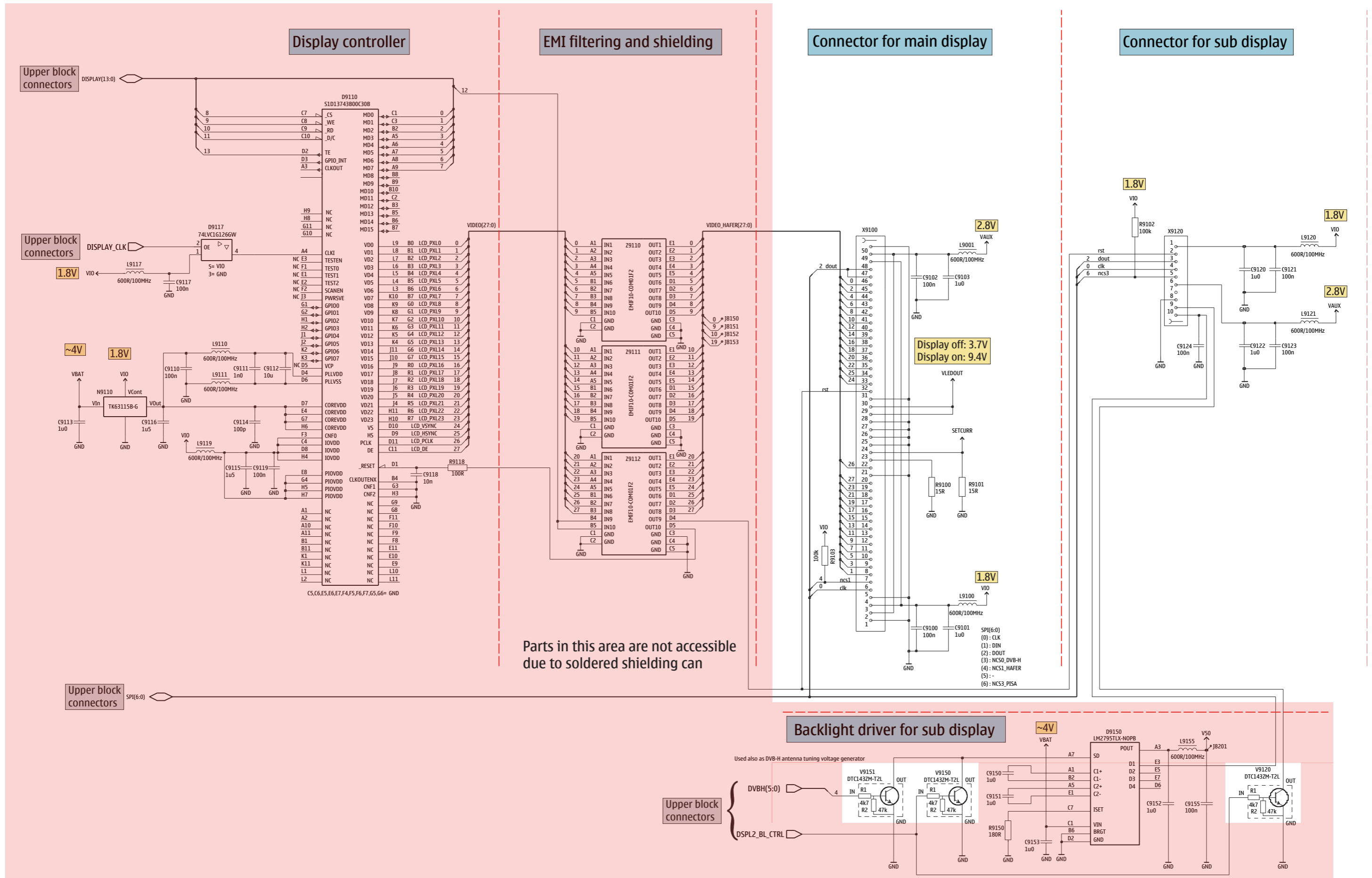

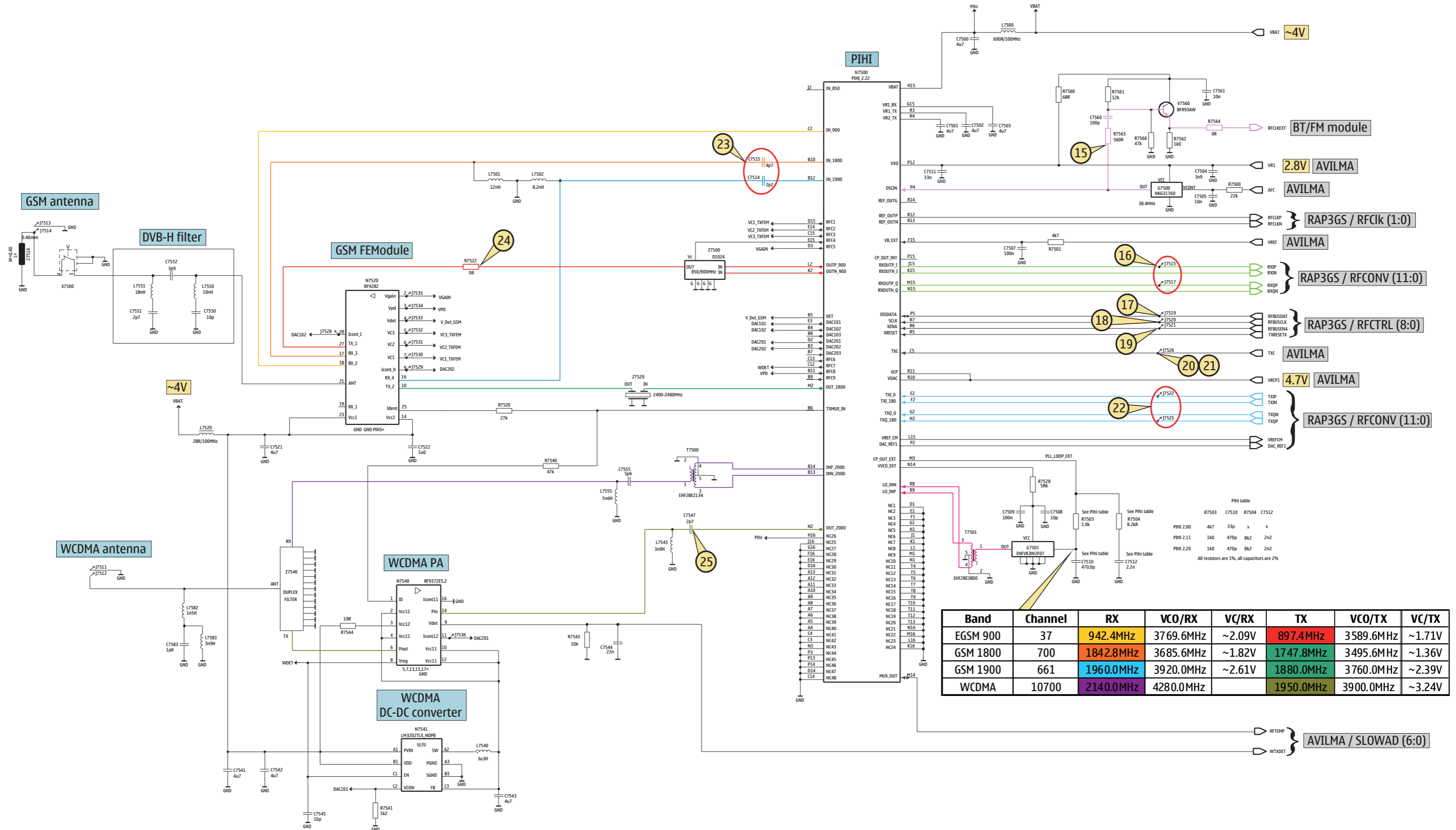

B	C2810	K7	C4460	S8	C7550	C7	L7555	F6	R6034	F9	
B2100	I11	C2811	J4	C4600	T7	C7551	C7	L7582	C2	R6036	E9
B2200	J10	C2812	L7	C4601	T7	C7552	C8	L7583	D2	R6040	E10
C	C2813	L7	C4602	T7	C7555	F6	N	R6302	D8		
C2000	R10	C2814	L5	C4603	T9	C7560	F7	N2100	K8	R6303	H8
C2002	M10	C2815	K4	C4800	M4	C7561	D7	N2101	K9	R6304	H8
C2003	M10	C2816	L5	C4801	O5	C7583	C2	N2200	J9	R6305	H8
C2005	N9	C2817	J4	C4802	O7	D	N2300	N8	R6306	E8	
C2006	N9	C2818	L7	C4803	M4	D2800	K6	N4200	M8	R6307	G7
C2009	M10	C2819	K4	C4804	L6	D3000	K6	N4420	T5	R7500	E3
C2010	M10	C2820	J7	C4805	O5	D4400	O7	N4430	G5	R7501	F6
C2012	R10	C2821	L7	C4806	N7	D4800	N5	N4441	S9	R7503	F3
C2013	R10	C2822	K4	C4807	L5	D5000	N3	N4442	T9	R7504	F3
C2070	R9	C3100	I7	C4808	L5	D5200	S7	N4450	P4	R7520	C7
C2071	Q7	C4200	L7	C4809	M4	D6035	C9	N4600	T7	R7522	F6
C2100	I10	C4201	M7	C4810	O4	F	N6300	E9	R7528	F2	
C2120	K9	C4202	N7	C4811	L6	F2000	R10	N6301	E8	R7540	B3
C2121	K9	C4224	T5	C4812	N7	G	N6302	F8	R7541	C4	
C2123	L8	C4226	T6	C5000	M2	G2200	G9	N6303	H8	R7543	D2
C2124	K9	C4401	S7	C5001	M2	G7500	E3	N7500	E5	R7544	B3
C2125	K9	C4402	S7	C5002	M2	G7501	F3	N7520	C6	R7560	E7
C2127	I10	C4403	O9	C5003	M2	L	N7540	C3	R7561	E7	
C2128	I10	C4404	S7	C5004	M4	L2000	R10	N7541	C4	R7562	E7
C2129	I10	C4405	O7	C5005	M3	L2001	N10	R	R7563	D3	
C2130	K10	C4406	S6	C5006	M2	L2002	M9	R2006	M9	R7564	E7
C2131	K10	C4407	R6	C5200	T7	L2003	M9	R2007	O9	R7565	E7
C2132	K10	C4408	R8	C5201	R7	L2004	O10	R2009	N9	R7566	E7
C2133	L10	C4409	S8	C5202	R7	L2005	O10	R2010	R10	S	S10
C2135	L9	C4410	S8	C6040	B9	L2006	O10	R2011	N9	S4440	S10
C2135	L9	C4411	S10	C6041	D9	L2010	M10	R2012	N9	T	
C2200	K9	C4412	S10	C6042	D9	L2120	L9	R2013	N9	T7500	F6
C2201	I9	C4413	R10	C6043	K7	L2121	J10	R2014	N9	T7501	F3
C2202	K9	C4414	T10	C6044	J7	L2122	K10	R2015	N10	V	
C2205	K9	C4415	T10	C6047	E10	L2123	K10	R2071	I8	V2300	O8
C2211	I8	C4416	T10	C6300	F10	L2124	K10	R2200	K9	V2303	O8
C2213	I9	C4417	S10	C6301	F9	L2202	J8	R2302	P8	V4420	T5
C2215	I9	C4418	S10	C6302	E8	L2203	I8	R2800	L6	V4430	I7
C2216	I10	C4419	S10	C6303	E8	L2204	I9	R2801	K4	V4436	I7
C2217	K9	C4420	T6	C6304	H7	L2205	K8	R2802	L4	V4437	H5
C2220	J8	C4421	T5	C6305	H9	L2206	I8	R2803	L4	V4438	I5
C2222	I8	C4422	T6	C6306	E9	L2301	N9	R4400	N7	V6300	D8
C2225	J8	C4423	S10	C6310	H9	L2302	M9	R4401	N7	V6301	E8
C2226	I9	C4424	R10	C7500	G5	L2304	O9	R4403	M7	V7560	E7
C2227	I9	C4425	S10	C7501	E3	L4200	M8	R4405	P10	X	
C2228	I8	C4426	R8	C7502	E3	L4201	N7	R4420	T5	X2000	Q11
C2231	K8	C4427	R8	C7503	G5	L4401	S7	R4424	R8	X2001	N11
C2232	I8	C4428	R8	C7504	E2	L4404	P9	R4428	O4	X2060	O5
C2300	N9	C4429	R8	C7505	E3	L4406	R6	R4429	Q7	X2070	P6
C2301	N9	C4430	G4	C7506	G4	L4408	S8	R4430	I7	X2700	J2
C2302	L9	C4431	H4	C7507	F6	L4411	S10	R4431	I7	X4400	S9
C2303	N7	C4433	G5	C7508	F2	L4414	T10	R4439	H5	X4401	S6
C2304	N8	C4435	H4	C7509	F2	L4417	S10	R4440	S6	X4402	S10
C2307	N7	C4437	H5	C7510	F3	L4420	S5	R4441	S6	X4403	Q8
C2308	P8	C4438	P5	C7511	E2	L4423	R10	R4442	M7	X6030	F10
C2309	O9	C4439	R7	C7512	F3	L4426	R8	R4450	T7	X7500	C8
C2312	O8	C4440	S8	C7514	F6	L4429	S8	R4601	T9	Z	
C2314	O8	C4441	S8	C7515	E6	L4430	G6	R4800	M4	Z4400	T6
C2700	H2	C4442	R9	C7521	D7	L4435	H5	R4809	L5	Z4401	S7
C2800	L6	C4443	S9	C7522	C5	L4441	S8	R5100	M7	Z4402	R7
C2801	J6	C4444	T9	C7540	B3	L6300	E9	R5200	R6	Z4404	S9
C2802	L6	C4445	T9	C7541	C4	L7500	G4	R5201	S9	Z4405	S5
C2803	L4	C4446	T8	C7542	C4	L7501	E6	R5210	S9	Z4410	Q10
C2804	J4	C4450	T7	C7543	B4	L7502	F6	R5211	S9	Z4411	R8
C2805	K7	C4451	T7	C7544	D3	L7520	D4	R5220	M7	Z7500	E6
C2806	K7	C4452	I4	C7545	C2	L7540	C4	R6030	D8	Z7520	C5
C2807	J7	C4453	R10	C7546	C4	L7543	D3	R6031	D9	Z7540	C2
C2808	J6	C4454	R10	C7547	D3	L7550	D8	R6032	F9		
C2809	L6	C4459	R8	C7548	D3	L7551	C8	R6033	F9		

